

## IP 65 Flood Light

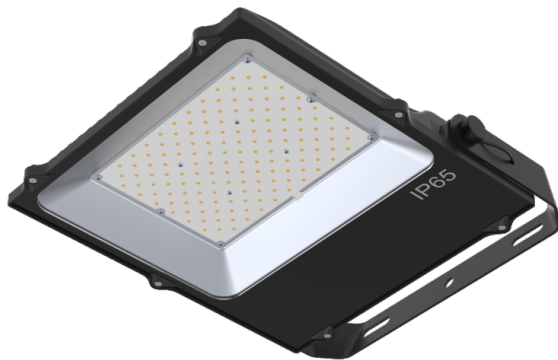

### FEATURES

- IP65 rated
- Easy installation and maintenance
- Corrosion and rust proof
- 50,000 hours lifetime

### SUITABLE APPLICATIONS

- Area Lighting
- Parking lot Auto Dealerships
- Shopping malls
- Building lighting
- Warehouse lighting
- Wall lighting

### CONSTRUCTION:

Heavy die-cast aluminum alloy housing with black powder-coated finish. Glass lens.

### ELECTRICAL:

Available as 120-277V input. -36°C to 60°C.

### OPTICAL SYSTEM:

Lumileds 3030LED chips. High quality tempered glass optics. 120° beam angle.

### INSTALLATION & MOUNTING:

Wall/Square Pole Mounting with quick mount back plate for easy installation.

### WARRANTY:

5-year limited warranty. Actual performance may differ as a result of end-user environment and application.

### PERFORMANCE

Model NO	Power Factor	Wattage	Voltage/Current Input		Light Efficiency	Kelvin Options
			120V	277V		
LS-FLC100W-50K	0.9	100W	0.83A	0.36A	130LM/W	5000K
LS-FLC150W-50K	0.9	150W	1.25A	0.54A	130LM/W	5000K
LS-FLC200W-50K	0.9	200W	1.66A	0.72A	130LM/W	5000K

# Flood LED Luminaire

## Electric Characteristic

Specification/Model	LS-FLC100W-50K	LS-FLC150W-50K	LS-FLC200W-50K
LED Chips	3030 SMD LED		
Input power	100W	150W	200W
Lumens output	14000LM	21000LM	28000LM
Efficiency	140LM/W	140LM/W	140LM/W
CRI	>72	>72	>72
Color Temperature	5000K	5000K	5000K
Input voltage	120-277V/AC	120-277V/AC	120-277V/AC
Light distribution type	120D	120D	120D
Working temperature	-36+60°C	-36+60°C	-36+60°C
Junction temperature	<75°C	<75°C	<75°C
lamps efficiency	≥90%	≥90%	≥90%
Certificate	ETL CETL DLC	ETL CETL DLC	ETL CETL DLC
Equivalent	150-300W MH/HPS	300-450W MH/HPS	450-800W MH/HPS

## DIMENSION

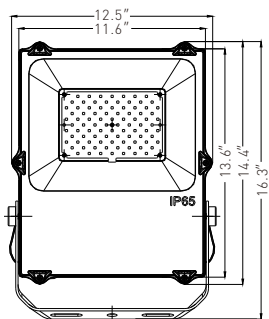

LS-FLC100W-50K

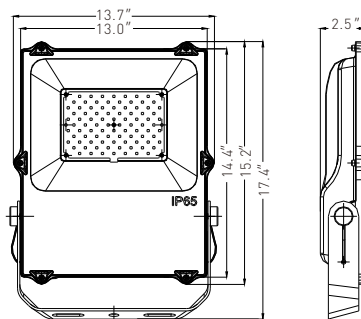

LS-FLC150W-50K

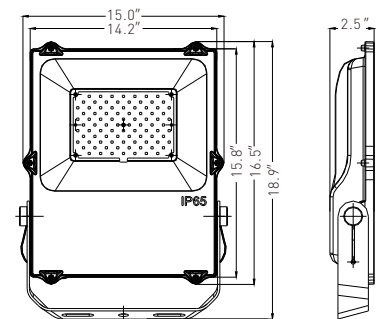

LS-FLC200W-50K

## DISTRIBUTION DIAGRAM

LS-FLC100W-50K

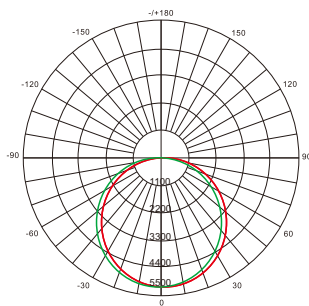

AVERAGE BEAM ANGLE(50%): 111.1°

UNIT:CD  
 Test Number:LS-FLC100W-50K  
 Lumens:14000LM  
 Test Number:100W  
 Test Number:5000K  
 - C0/180,112.9  
 - C30/210,111.5  
 - C60/240,109.7  
 - C90/270,110.1

LS-FLC150W-50K

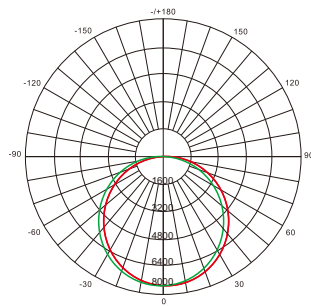

AVERAGE BEAM ANGLE(50%):111.9°

UNIT:CD  
 Test Number:LS-FLC150W-50K  
 Lumens:21000LM  
 Test Number:150W  
 Test Number:5000K  
 - C0/180,113.5  
 - C30/210,111.8  
 - C60/240,111.9  
 - C90/270,110.3

LS-FLC200W-50K

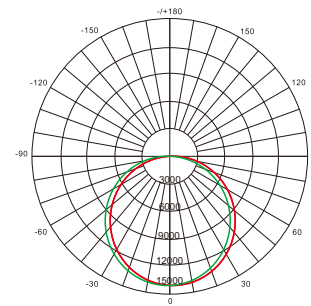

AVERAGE BEAM ANGLE(50%): 112.9°

UNIT:CD  
 Test Number:LS-FLC50W-50K  
 Lumens:7000LM  
 Test Number:50W  
 Test Number:5000K  
 - C0/180,114.5  
 - C30/210,112.2  
 - C60/240,111.6  
 - C90/270,113.3